

HAD-129-84-36

12,900 lbs. Capacity

PALFINGER HOOKLIFT



STANDARD FEATURES INCLUDE:

- Available with 36" hook height
- 10ft and 12ft containers

CHASSIS REQUIREMENTS

- 84" C.A. with 48" A.F. (Ford F-550 with rear fuel tank)
- 96" C.A. with 36" A.F.

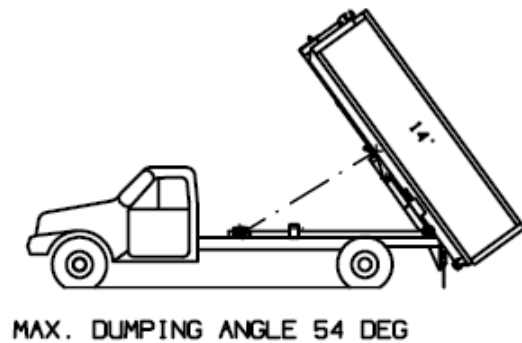
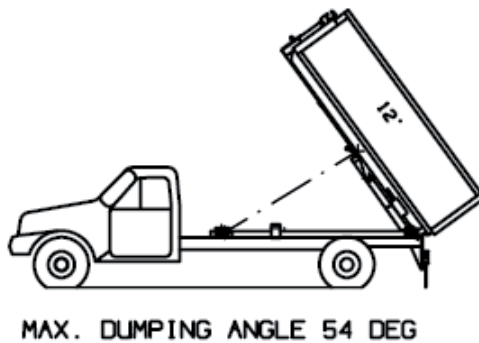
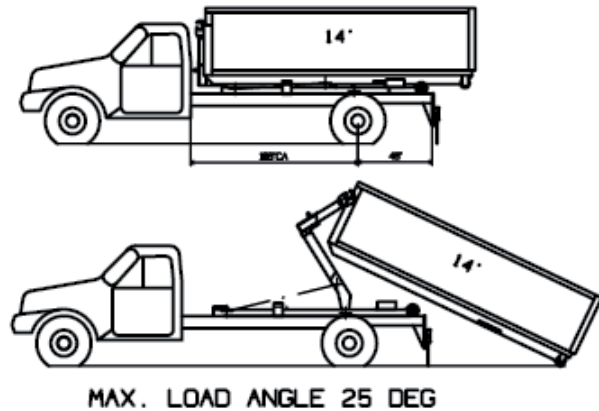
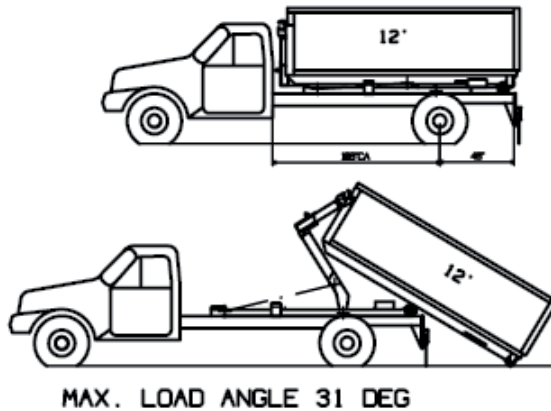

FEATURES:

- 12,900 LBS Capacity
- High dump, "True Dump Truck" style dumping dual pivot
- Designed and manufactured in the United States
- Low pressure 2800 PSI hydraulics easily adapts to hydraulic based accessories
- Dual lift cylinders for added strength and stability
- Sliding jib to accommodate short containers and adjust the weight distribution
- Dual rear rollers side for easy container movement
- Poly fenders with full width bumper
- LED stop, turn and marker lights with factory plug-in harness
- Pintle hook mounting plate is standard
- Patented floating jib eliminates all electromechanical controls and allows the body to be slid back during the dump mode
- US manufactured pump, valve, cylinders and fittings
- All models include an A-frame drawing

CUSTOMIZED QUICK CHANGE BODIES:

- Open top containers
- Closed storage bodies
- Salt and sand spreaders
- Tree spraying units
- Septic cleaning pumps
- Hydroseeders
- Concrete forms
- Scaffold delivery skids
- Recycling containers
- Flatbed bodies
- Dump bodies (standard & heated)
- Water tanks
- Spraying systems
- Liftgate bodies
- Cranes: skid mounted
- Bark mulch blowers
- Contractor bodies